



Clear
Comfort

Swim Happy.™

Clear Comfort's CCW100 Pool & Spa System

Patented Hydroxyl-Based Advanced Oxidation (AOP)

Installation, Operations & Maintenance
Manual

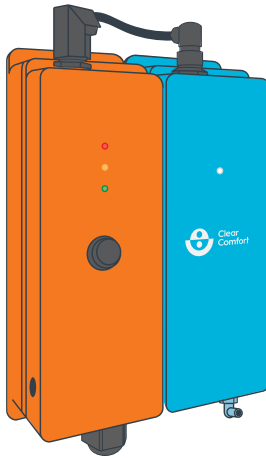

IMPORTANT SAFETY INSTRUCTIONS

For further assistance contact us:

303.872.4477

support@clearcomfort.com

clearcomfort.com

V.13.0.40



**Clear
Comfort**

For the latest version, please visit:

clearcomfort.com/ccw100-manual

Clear Comfort’s CCW100 System
Installation, Operations & Maintenance Manual

WARRANTY 2

GENERAL INFORMATION 3

 Important Safety Instructions 3

 Electrical Safety 4

 Grounding 4

 General Safety 4

DESCRIPTION FOR STANDARD CLEAR COMFORT SYSTEMS 5

 Key Features 5

 Operating Ranges 5

 Light Functionality 6

INSTALLING THE CLEAR COMFORT SYSTEM 7

 Standard Clear Comfort Installation Kit 7

 Recommended Materials and Tools 7

 System Installation 8

 Electrical Installation - General 8

 Electrical Installation - Directly to Pump Circuit 9

 Electrical Installation - Wall Outlet 9

 Cartridge Connection 10

INSTALLING THE CLEAR COMFORT MANIFOLD INJECTION 11

 Full System Diagram: Manifold Injection 11

 Manifold Installation 12

 Connecting Clear Comfort System to Manifold Venturi 14

 Air Flow Meter 16

 Operating Instructions 17

FULL SYSTEM INTEGRATION DIAGRAMS 18

 Full System Diagram: Inline Chlorine Feeder 18

 Full System Diagram: Offline Chlorine Feeder 18

 Full System Diagram: Salt Water Chlorine Generator 19

 Full System Diagram: UV System 19

SYSTEM MAINTENANCE 20

 Cartridge Replacement 20

BASIC WATER CARE 22

FREQUENTLY ASKED QUESTIONS 23

WIRING 24

Clear Comfort warrants all Equipment to be free from defects in material or workmanship under normal use and service. Clear Comfort, Inc. at its discretion may repair or replace the Equipment or parts thereof. The Company's warranty does not cover any Equipment that has been altered or changed in any way by any person not authorized by Clear Comfort, Inc..

THIS CONSTITUTES THE SOLE WARRANTY MADE BY CLEAR COMFORT, INC. EITHER EXPRESSED OR IMPLIED. THERE ARE NO OTHER WARRANTIES EXPRESSED OR IMPLIED WHICH EXTEND BEYOND THE FACE HEREOF, INCLUDING THE IMPLIED WARRANTIES OF MERCHANTABILITY AND FITNESS FOR A PARTICULAR PURPOSE. IN NO EVENT WILL CLEAR COMFORT, INC. BE LIABLE FOR ANY INCIDENTAL OR CONSEQUENTIAL DAMAGES AND CUSTOMER'S REMEDIES ARE LIMITED TO REPAIR OR REPLACEMENT OF NONCONFORMING CLEAR COMFORT SYSTEMS OR PARTS.

This equipment was inspected before shipment from our plant. To original purchasers of this equipment, Clear Comfort Water Inc. ("Clear Comfort"), warrants its Clear Comfort Systems to be free from defects in materials and workmanship for a period of FIVE (5) years from the date of purchase. Replacement Cartridges and cylinders are warranted for a period of ONE (1) year from the date of purchase.

Parts which fail or become defective during the warranty period, except as a result of freezing, negligence, improper installation, use, or care, shall be repaired or replaced, at our option, without charge, within 90 days of the

receipt of defective product, barring unforeseen delays.

To obtain warranty replacements or repair, defective components or parts should be returned, transportation paid, to the place of purchase, or to the nearest authorized Clear Comfort service center. For further Clear Comfort dealer or service center information, contact Clear Comfort customer service department.

Clear Comfort shall not be responsible for cartridge, removal and/or re-installation labor or any other such costs incurred in obtaining warranty replacements.

The Clear Comfort Products warranty does not apply to components manufactured by others. For such products, the warranty established by the respective manufacturer will apply.

This warranty shall be voided if at any time: (i) Customer attempts to make any internal changes to any of the components of the Equipment; (ii) the power supplied to any part of the Equipment exceeds the Equipment's operating parameters; (iii) any external device attached by Customer creates conditions exceeding the Equipment's operating parameters; (iv) the Equipment is tampered with; or (v) the serial number is covered, removed or defaced. Clear Comfort, Inc. reserves the right to seek damages if its system is tampered with, reverse engineered, or if Customer takes any other actions to interfere with the operation or integrity of the Clear Comfort system

To activate and validate your warranty, you must submit your warranty card or fill out our warranty form on clearcomfort.com/warranty within 1 year of your ship date from Clear Comfort.

CONTACT INFORMATION:

Tel: 303.872.4477

Operations: support@clearcomfort.com
clearcomfort.com

IMPORTANT SAFETY INSTRUCTIONS

1. READ AND FOLLOW ALL INSTRUCTIONS.

2. For cord connected/convertible units: DANGER – Risk of injury.

A. Replace damaged cord immediately.

B. Do not bury cord.

C. Connect to a grounding type receptacle only.

3. For all permanently connected units intended for use on 15 or 20 ampere, 125V or 230V, single phase branch circuits: WARNING – Risk of Electric Shock. Connect only to a branch

circuit protected by a ground-fault circuit-interrupter (GFCI). Contact a qualified electrician if you cannot verify that the circuit is protected by a GFCI.

4. For all cord connected units other than storable pool pumps: WARNING – Risk of Electric Shock. Connect only to a grounding type receptacle protected by a ground-fault circuit interrupter (GFCI). Contact a qualified electrician if you cannot verify that the receptacle is protected by a GFCI.

5. For all permanently connected units: WARNING – Risk of Electric Shock. Connect only to a branch circuit protected by a ground-fault circuit-interrupter (GFCI). Contact a qualified electrician if you cannot verify that the receptacle is protected by a GFCI.

6. For units intended for above-ground storable swimming pools: Do not bury cord. Locate cord to minimize abuse from lawn mowers, hedge trimmers, and other equipment.

7. For all cord and plug connected units: WARNING – To reduce the risk of electric shock, replace damaged cord immediately.

8. For units intended for above ground storable swimming pools:

WARNING – To reduce the risk of electric shock, do not use extension cord to connect unit to electric supply; provide a properly located outlet.

9. CAUTION: At low or no flow conditions, gas may accumulate – ensure system is off when backwashing or when water is not being treated to prevent an unsafe gas buildup. Pressure switches, flow switches and other safety equipment to prevent unsafe gas buildup is recommended.

10. When the modified air is introduced into the pool or spa water via the existing plumbing, the biocide is produced. Some of the remaining activated atoms either keep minerals dissolved in the water or remove minerals that were previously deposited.

11. This unit is to be installed in accordance with the installation instructions, the applicable plumbing and building codes, the applicable state and local laws and regulations, and the requirements of the Authority Having Jurisdiction.

12. When installing and using this equipment, basic safety precautions should always be followed including the following.

13. WARNING - To reduce the risk of injury, do not permit children to use this product unless they are closely supervised at all times.

14. WARNING - Do not sit or stand on unit.

15. SAVE THESE INSTRUCTIONS.

ELECTRICAL SAFETY

- Do not service the machine when the power is ON.
- The power supply wire gauge and insulation must meet the temperature and power requirements.
- To avoid personal injury never touch exposed electrical connections or components while the power is ON.
- Do not install/service the Clear Comfort system if you or the machine is standing in water with the power ON.
- Protect the power cord from being walked on or pinched, particularly at plugs and the point where they exit from the system.
- The device must be properly connected to the correct power source (either 60Hz 120V or 230V) using the supplied power cord in accordance with the local electrical code. If possible the unit should be hardwired to the pump circuit and controlled by the pump circuit (rather than hardwiring, an appropriate 120V or 230V receptacle outlet and plug may be used to connect to

the pump controlled circuit). If the unit is being wired to standalone AC power (i.e., not through the pump circuit on either 120V or 230V) it should be installed with its own timer circuit and plugged in through a Ground Fault Circuit Interrupt (GFCI) and the timer should be set to reflect the pool or tub's hours of operation. Regardless if hardwired or standalone connected, the electrical connection must be made in accordance with the local electrical code.

GROUNDING

The Clear Comfort, Inc. system must be properly grounded. An electrical ground connection to a reliable earth ground is essential for safe operation. Without an electrical ground, all accessible conductive components (including knobs and controls that appear insulated) can render an electrical shock.

GENERAL SAFETY

Use personal protective equipment (steel toe shoes, hearing protection, eye protection) when installing the Clear Comfort system. Follow ladder safety requirements.



KEY FEATURES

This manual describes how to install, operate and maintain the standard Clear Comfort system. The Clear Comfort system can be installed in a few hours with little or no disruption to the recirculation or electrical systems. After the Clear Comfort system is installed, it is ready to start treating the water immediately. The Clear Comfort system protects pool or spa water (biocide, scale control and corrosion control) without the harsh effects of salt chlorine, high cyanuric acid or high chlorine levels. The pool or spa water still needs to be tested, as would be done with a traditional treatment system.

OPERATING RANGES

Power: 120V or 230V receptacle with approximately 10 watts.

Ballast: 120V or 230V

Electrical Requirements: 120V, 60Hz

Electrical Rating: 120V, 60Hz, 1.0Amp or 230V, 60Hz, 0.5Amp

NOTE: CLEAR COMFORT SHOULD ONLY RUN WHEN THE PUMP IS OPERATING

FRONT VIEW

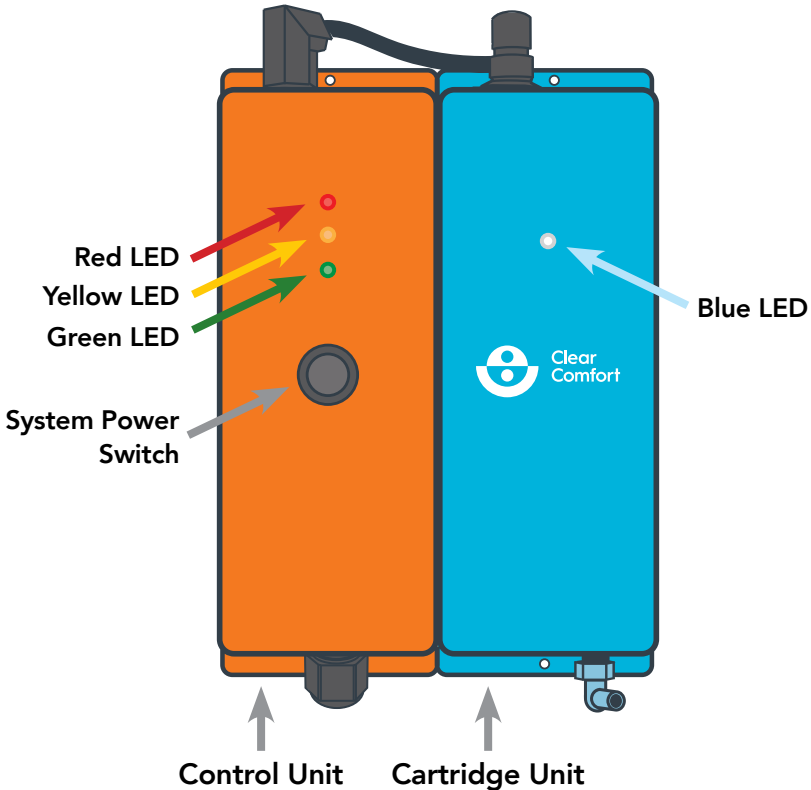

Figure 1: System Functions

LIGHT FUNCTIONALITY

Green Light: System is on and operating properly.

Yellow Light: Cartridge Unit has reached 80 percent of its life expectancy (8,000 hours) and it's time to purchase a replacement cartridge.

To exchange your Cartridge Unit, please visit: clearcomfort.com/cartridge

Red Light: Cartridge Unit has reached its life expectancy and needs to be replaced.

Blue Light: Operation light that should always be illuminated.

Prior to installation, a site survey should be performed to validate that the correct system parameters are in place and ready for installation. We recommend that you maintain compliance within the following operating ranges for well constructed and circulated pools.

- **Max. flow rate treated:** 90 Gallons Per Minute (GPM)
- **Type of pool/spa filter:** Any ANSI 50 approved filtration.
- **Type of pump:** Variable speed pump is highly recommended.
- **Voltage of power supply:** 120V or 230V AC.
- **Maximum distance from injection point:** Air Tubing length should be as short as possible with no more than 10 feet from the system to the Manifold/Venturi injection location.
- **Indoors or outdoors:** Either is suitable. It is recommended to install away from upward facing sprinklers.
- **Water quality at installation:** The water quality should be balanced prior to installing the Clear Comfort system.

STANDARD CLEAR COMFORT INSTALLATION KIT

- Option 1: Manifold
- Option 2: Venturi
- Air Check Valve
- 10' Air Tubing
- Flow Meter and Barbed Connector
- Conduit Connector
- Conduit Box and Lid
- 12" Conduit Tubing

RECOMMENDED MATERIALS AND TOOLS

- A power drill and proper hardware for mounting the Clear Comfort system.
- Proper plumbing materials and tools for Manifold injection installation.

SYSTEM INSTALLATION

1. Determine the best location to mount the Clear Comfort system. Screw in the top mounting bracket first, and then the bottom mounting bracket of the Control Unit (orange unit). Mount the Cartridge Unit (blue unit) by securely fastening the Cartridge Unit to the Control Unit using side keyed brackets, and screw in the top mounting bracket first, and then the bottom mounting bracket.
2. System must be installed no more than 10 feet from injection location.
3. Where possible, ensure system location is at least one (1) foot above the water line of pool/spa and Manifold/Venturi injection site.

ELECTRICAL INSTALLATION - GENERAL

1. Follow all local and national electric codes.
2. Determine if the Clear Comfort system will be powered by 120V or 230V. **NOTE:** All units are factory set to 230V. If your system will be powered by 230V, skip to Step 4.

3. Set the switch on the ballast on the orange Control Unit: Remove plug in the left side of the Control Unit. With a small screwdriver, slide the switch in the appropriate direction according to the label on the Control Unit. Re-install the plug. See Figure 2.

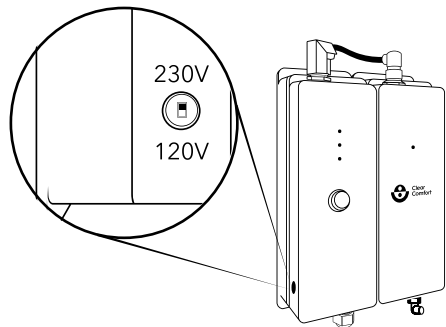

Figure 2: Ballast Electrical Switch

4. The Clear Comfort system comes with a 12 inch section of 1/2 inch flexible conduit, a water-tight conduit fitting, and a conduit body that may be easily converted into the shape preferred for the particular installation.
5. If 12 inches is too long, cut to the desired length. Slide the wires from the Clear Comfort system through the conduit, insert the conduit into the water tight connector on the Clear Comfort system, and tighten down.
6. Configure the conduit body as needed for the installation into the desired shape (LL, LB, LR, or C), and attach the water-tight conduit fitting to the body.
7. Slide the conduit and wire into the conduit body and tighten down the water-tight connection.

8. Run wire (and conduit, if required by local code) from the pump circuit to the conduit body using water-tight fittings.
9. Using appropriately sized wire nuts inside the conduit body, connect the switched power to the Clear Comfort system.

NOTE: CLEAR COMFORT SHOULD ONLY RUN WHEN THE PUMP IS OPERATING

ELECTRICAL INSTALLATION - DIRECTLY TO PUMP CIRCUIT (RECOMMENDED)

1. Direct pump circuit connection is recommended. Unit should be hardwired to the pump circuit and controlled by the pump circuit.
2. The device must be properly connected to the correct power source (either 60Hz, 120V or 230V) using the supplied power cord, in accordance with the local electrical code.
3. Remove protective ballast switch cover. Toggle ballast switch between 120V and 230V to match required voltage. See Figure 2. Ensure white marked saddle switch matches correct voltage.
4. If hard wired, cord supplied must be hard wired in accordance to the National Electrical Code and in accordance with local regulations.
5. Test for proper grounding and secure connections.

NOTE: WIRE THE SYSTEM TO RUN ONLY WHEN THE PUMP IS RUNNING

ELECTRICAL INSTALLATION - WALL OUTLET

1. If the unit is being wired to standalone 120V AC power (i.e., not through the pump circuit), connect Clear Comfort system to the pool timing clock so that the system operates simultaneously with pool pump through a Ground Fault Circuit Interrupt (GFCI). In either case, the electrical connection must be made in accordance with the local electrical code.
2. Remove protective ballast switch cover. Toggle the ballast switch between 120V and 230V to match required voltage. See Figure 2.
3. Test for proper grounding and secure connections.

On page 11, Figure 4 shows the preferred installation that uses a Manifold injection.

CARTRIDGE CONNECTION

Gently align the notched outdent on the front of the Cable Connector with the keyed indent of the front of Cartridge Connector, as shown with the arrow in Figure 3. Seat the Cable Connector down onto the Cartridge Connector and turn the Cable Connector’s Collar a quarter-turn clockwise to lock the Cable and Cartridge Connector together. If a strange light pattern occurs, disconnect cable assembly and reconnect.

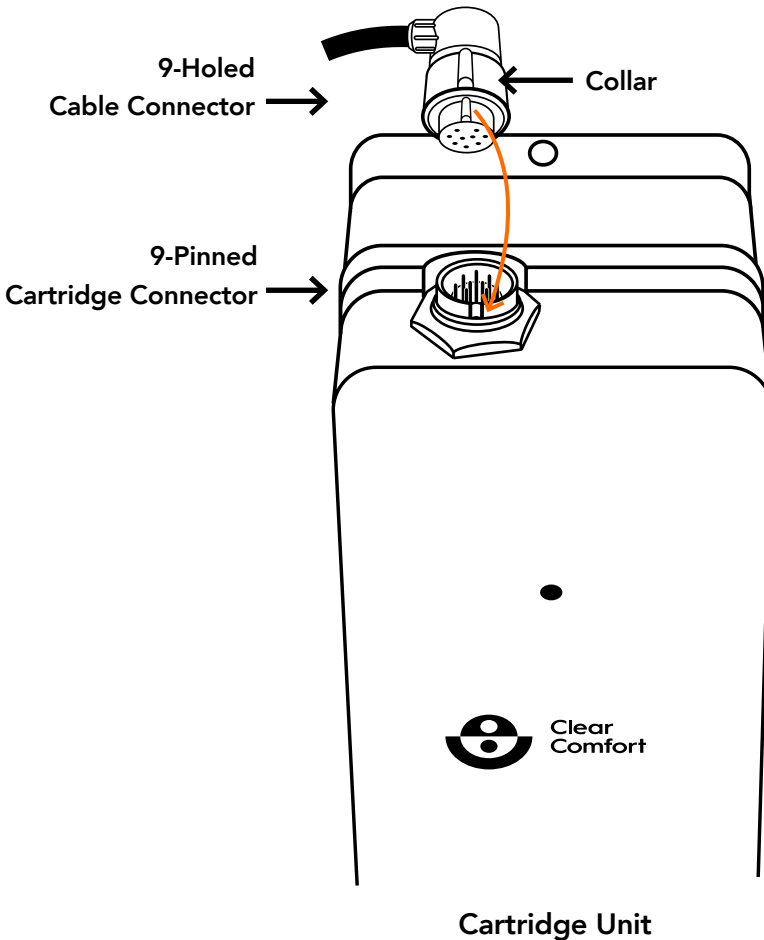

Figure 3: Cartridge Connection

FULL SYSTEM DIAGRAM: MANIFOLD INJECTION

NOTE: The Manifold injection is the preferred CCW100 installation method. For other U-bypass diagrams and instructions, please visit: clearcomfort.com/residential-manual

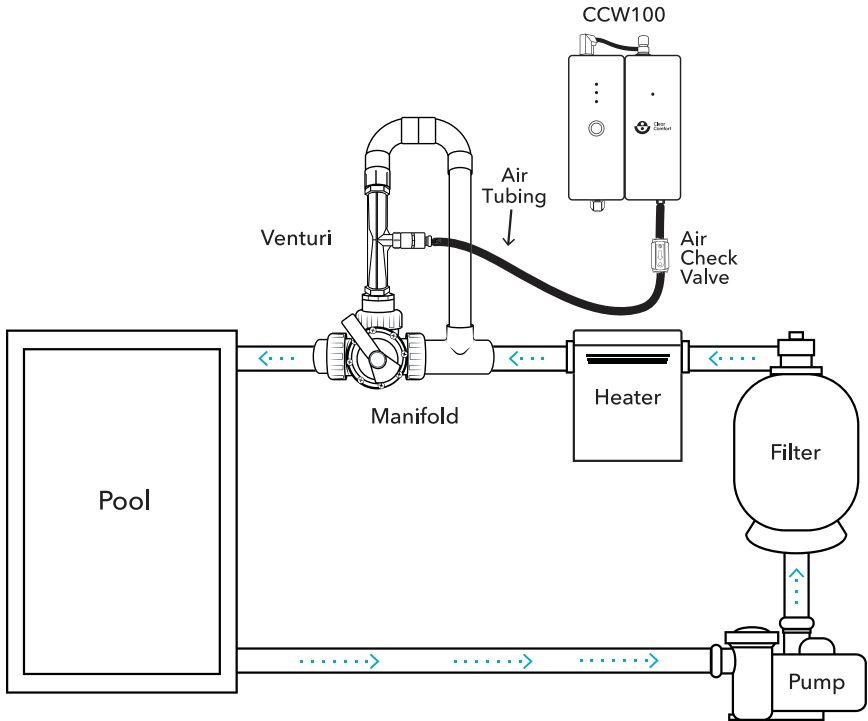

Figure 4: Full System Diagram With Manifold Injection

NOTE: For full system diagrams that include additional sanitation systems integrated with the Clear Comfort system, see pages 18 and 19.

MANIFOLD INSTALLATION (PREFERRED METHOD)

**PLEASE NOTE: TURN MAIN POOL PUMP OFF AND SWITCH OFF
MAIN CIRCUIT BREAKER.**

1. Pick a Location:

- Select a location to install Manifold, see Step 2 for proper water flow configuration position.
- If retrofitting, cut a 11" section of the main

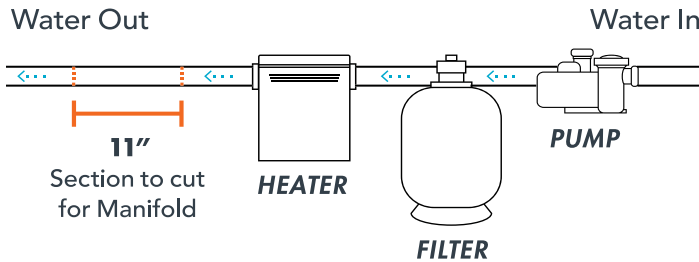

Figure 5: Manifold Location

2. Select Orientation

The 3-way valve unions allow you to install the Manifold either left-to-right or right-to-left to match your water flow configurations.

- If the water flow is going in the direction of the arrow on the Manifold, skip to Step 4.
- If the water flow is not going in the direction of the arrow on the Manifold, proceed to Step 3.

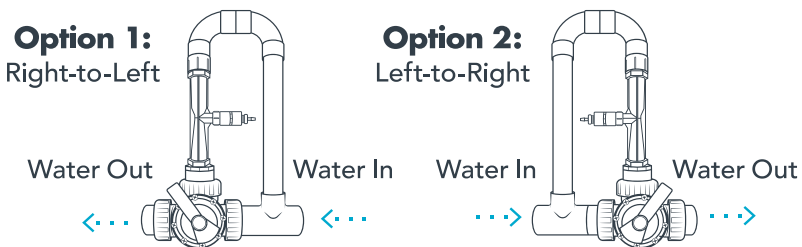
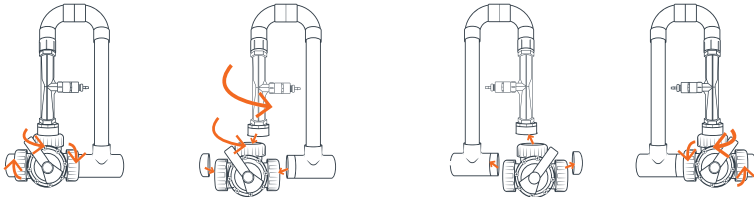

Figure 6: Manifold Orientation

3. Reverse 3-Way Valve (If Needed)

- Arrange 3-way valve by removing all three unions, as seen below.
- Once you have the 3-way valve facing the correct direction, connect the it to the Manifold by attaching all three unions.



1. Unscrew the 3 unions on 3-way valve.
2. Remove 3-way valve & horizontally flip Manifold & 3-way valve.
3. Align 3-way valve to the new Manifold position.
4. Attach the 3 unions on 3-way valve.

Figure 7: Manifold Reverse

4. Connect to Pool Plumbing

Put the Manifold into the 11" cut section of the pool plumbing.

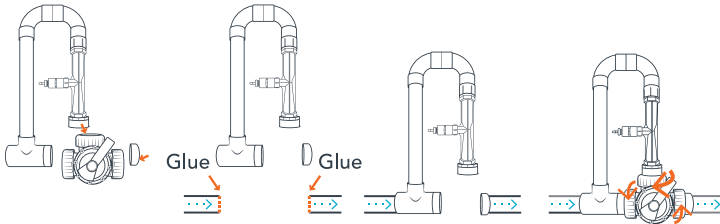

1. Unscrew the 3 unions & remove 3-way valve.
2. Glue the inflow & outflow slip fittings to the appropriate sides of the Manifold.
3. Attach the 3 unions on 3-way valve.

Figure 8: Connecting Manifold

5. Position 3-Way Valve

- Position the 3-way valve handle in between the Venturi & water out flow, as highlighted in Figure 9.
- Make adjustments, as necessary to set Venturi air suction to draw between 5 - 7 LPM using a Flow Meter. See page 16 for detailed instructions.

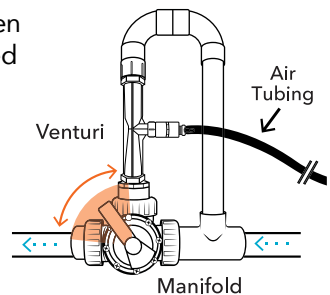

Figure 9: 3-Way Valve

NOTE: Failure to properly position the 3-way valve can result in an unwanted back-flow of water into the Clear Comfort system and other negative effects.

CONNECTING CLEAR COMFORT SYSTEM TO MANIFOLD VENTURI

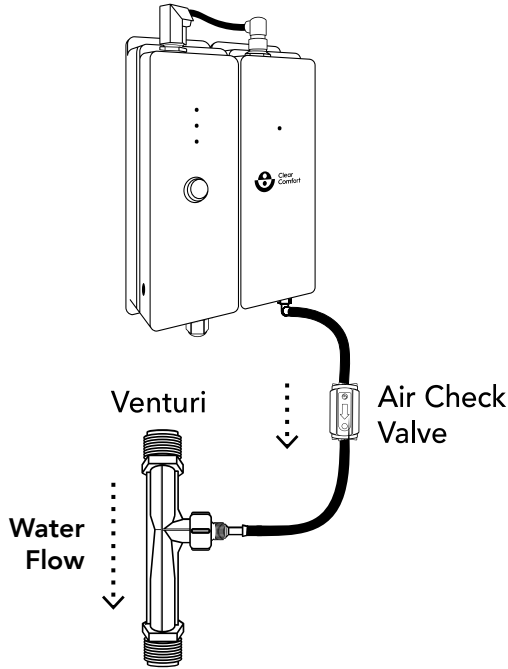

Figure 10: Venturi Connection

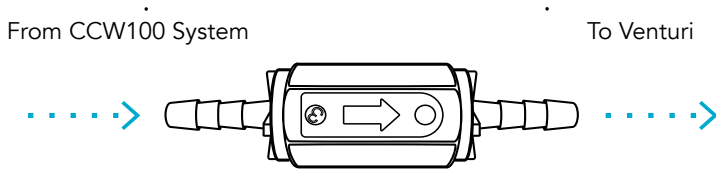

Figure 11: One-Way Air Check Valve

CONNECTING CLEAR COMFORT SYSTEM TO MANIFOLD VENTURI

1. Run provided 1/4-inch tubing from the Manifold injection port to the straight barb fitting. Length of tube should be less than 10 feet. Shorten and cut tubing as possible. See Figure 10.
2. If the unit is installed below the water line, install a loop in the 1/4-inch line known as a Hartford loop. Loop the Air Tubing so that at some point, tubing is above water level.

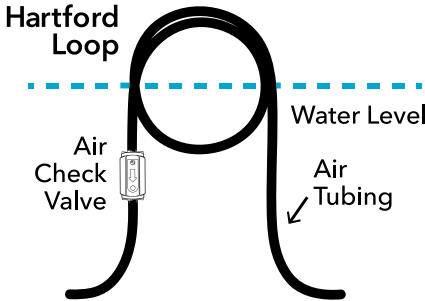

Figure 12: Hartford Loop

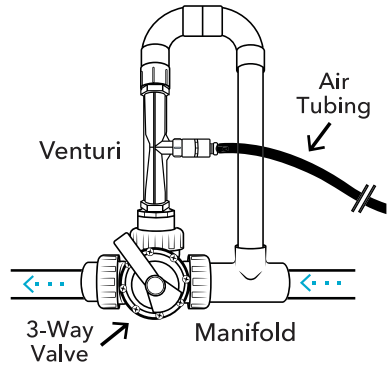

Figure 13: Manifold's 3-Way Valve

3. Install 1/4-inch one-way Air Check Valve (supplied) to eliminate any potential water back flow. See Figure 10 and 11 for details.
4. Gas exiting the Clear Comfort system to the Venturi connector port should flow easily.
5. Measure air suction using an Air Flow Meter and set Venturi air suction to draw between 5 - 7 LPM. See page 16 for detailed instructions.

AIR FLOW METER

1. Determine your variable speed setting and run your pump (2,400 RPM or higher).
2. Disconnect the blue Air Tubing from the Check Valve (between the Manifold and Check Valve)
3. Connect blue Air Tubing to the Flow Meter.
4. Adjust the Manifold's 3-way valve to increase/decrease pressure until the Flow Meter reads 5 - 7 LPM. **Note:** If RPM on variable speed pump is altered, readjust air suction.
5. When adjusted to 5 - 7 LPM, disconnect the flow meter and reconnect Air Tubing to the Check Valve. .

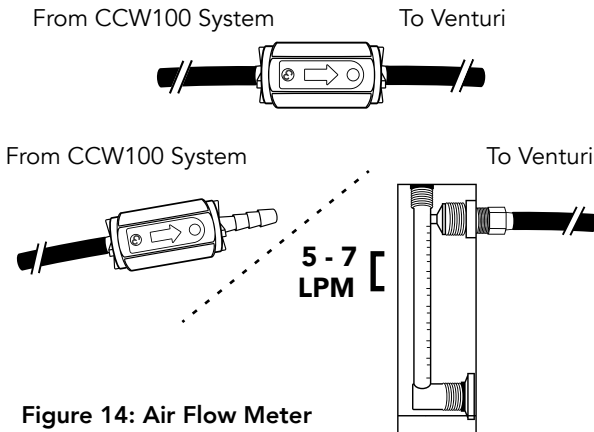

Figure 14: Air Flow Meter

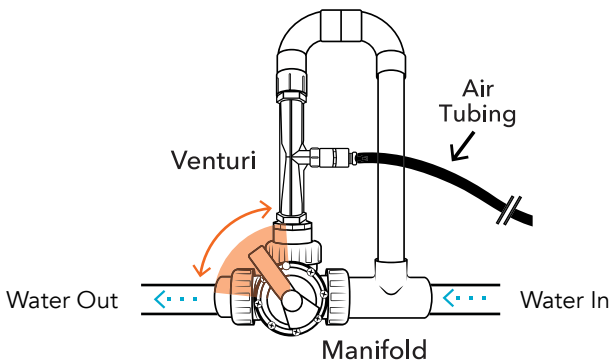

Figure 15: Adjusting 3-Way Valve

OPERATING INSTRUCTIONS

1. Install plumbing according to Figure 4.
2. Ensure the Manifold's 3-way valve is OPEN before turning pumps ON.
3. Turn pool/spa pump and filtration systems on.
4. Position the Manifold's 3- Way Valve
 - Position the 3-way valve handle in between the Venturi & water out flow, as highlighted in Figure 9.
 - Make adjustments, as necessary to set Venturi air suction to draw between 5 - 7 LPM using a Flow Meter. See page 16 for detailed instructions.
5. Toggle Clear Comfort system switch to the ON position.
6. Water entering the pool/spa should have bubbles exiting from at least one of the returns on to the body of water.

FULL SYSTEM DIAGRAM: INLINE CHLORINE FEEDER

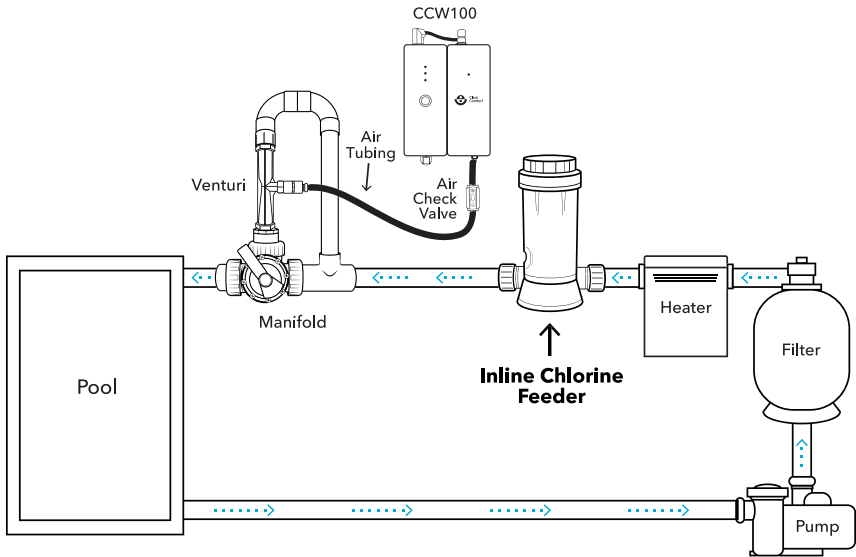

Figure 16: Inline Chlorine Feeder

FULL SYSTEM DIAGRAM: OFFLINE CHLORINE FEEDER

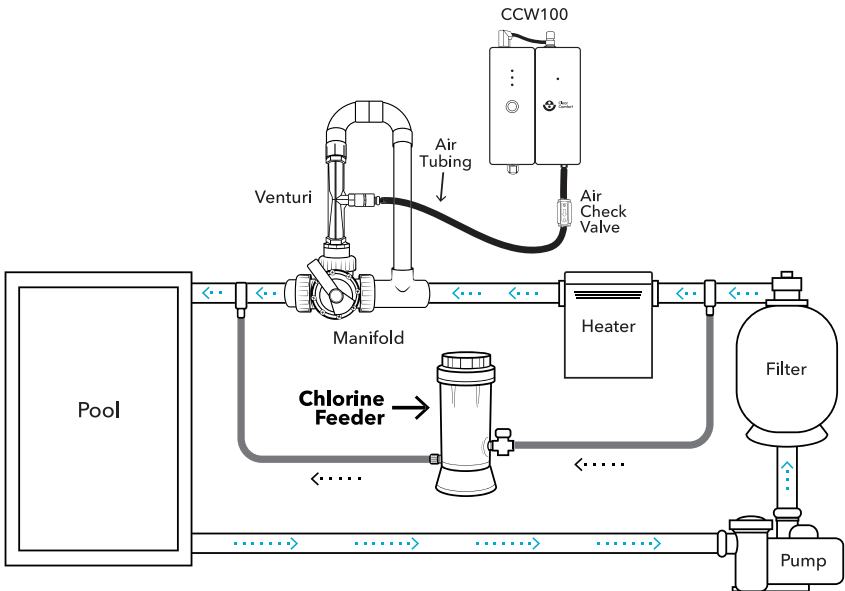

Figure 17: Offline Chlorine Feeder

FULL SYSTEM DIAGRAM: SALT WATER CHLORINE GENERATOR

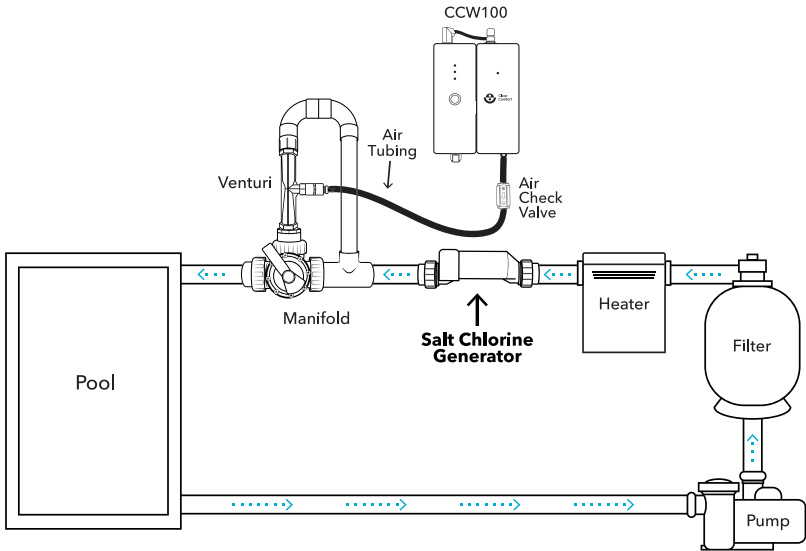

Figure 18: Salt Water Chlorine Generator

FULL SYSTEM DIAGRAM: UV SYSTEM

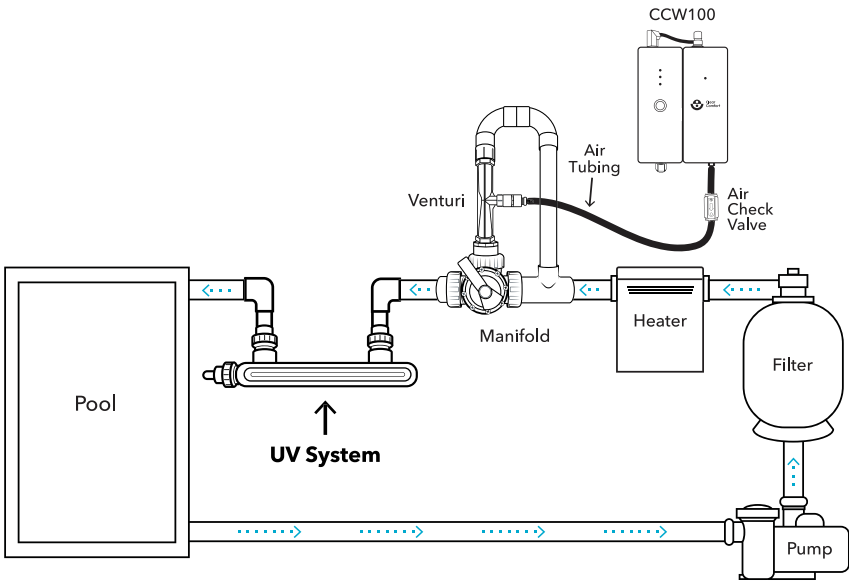
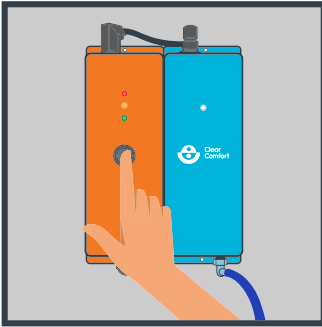

Figure 19: UV System

CARTRIDGE REPLACEMENT

The Cartridge Unit must be exchanged annually. No other maintenance is required. If the yellow OR red LED light is illuminated, the old Cartridge Unit must be exchanged and returned to Clear Comfort for proper recycling. For sustainability purposes, Clear Comfort provides a return-shipping label so the Cartridge Unit can be properly recycled.

To exchange your Cartridge Unit, please visit: clearcomfort.com/cartridge



1. Turn off and disconnect power to Clear Comfort system. Never attempt to service unit while it is wet. Ensure all LEDs on system front are off.

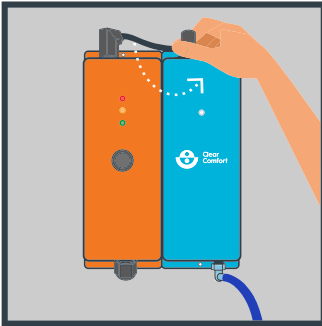

2. To remove the cartridge, disconnect Cartridge Unit from Control Unit by rotating the able Connector's Collar base quarter turn and gently pulling up.

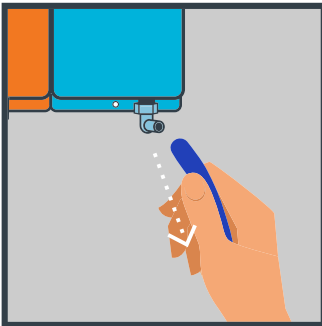

3. Remove the Air Tubing from bottom of Cartridge Unit.

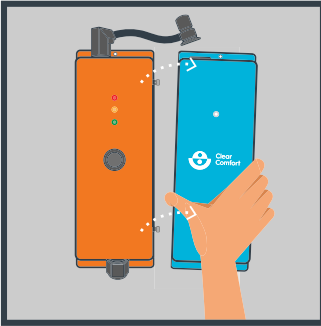

4. Remove Cartridge Unit from Control Unit.

Note: Please return old Cartridge Unit to Clear Comfort for proper recycling. For sustainability purposes, Clear Comfort provides a return-shipping label so the Cartridge Unit can be properly recycled.

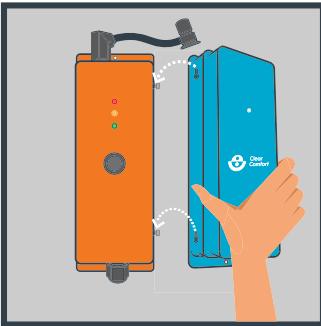

5. To install the replacement cartridge, securely fasten the Cartridge Unit to the Control Unit using the side keyed brackets.

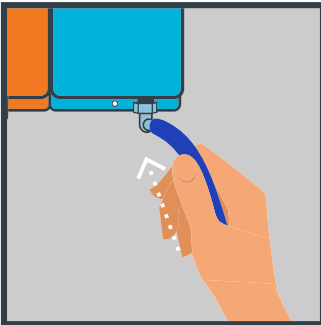

6. Reconnect the Air Tubing to bottom of the Cartridge Unit.
7. Remove old Air Check Valve from Air Tubing and replace with the new Air Check Valve.

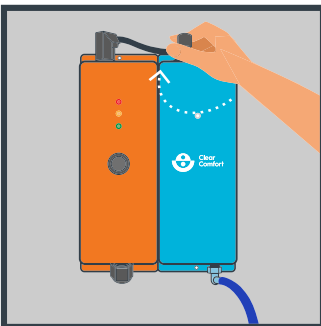

8. Reconnect top connection wire by inserting the Cable Connector into Cartridge Connector and turning a quarter turn, see Figure 3 for detailed instructions. If cable is properly connected, the system can be safely turned ON.

See Figure 1 for proper LED function. If strange light pattern occurs, disconnect cable assembly and reconnect.

BASIC WATER CARE

1. Run Clear Comfort 24/7:

- To get proper airflow from the Clear Comfort system, use a variable speed pump & set it between 2200 - 2400 RPM.
- If you're using a DE Filter, let it rest for 1 hour everyday

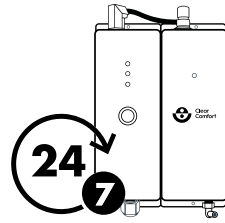

2. Balance Water

pH	7.2 - 7.4
Alkalinity	80 - 120 ppm
Cyanuric Acid	0 - 10 ppm
Calcium Hardness	200 - 400 ppm
Total Dissolved Solids (TDS)	Less Than 1,500 ppm
Residual Chlorine	0.5 - 1.5 ppm

3. Chlorine Options

	Manual Dosing	Automated Dosing
Cal Hypo (Calcium Hypochlorite)	Non-Stabilized Chlorine Tablets (poolife® NST®)	Tablet Feeder (CCH® Endurance or Other)
Liquid Chlorine (Sodium Hypochlorite)	Liquid Manual Dosing	Automated With Peristaltic Pump & ORP Sensor

4. Shock As Needed

- Option 1: Cal-Hypo granules
- Option 2: Liquid chlorine
- Option 3: Non-chlorine shock (not recommended for algae)

5. Algae Control

- Use a proactive 90-day algae treatment
- Chelated Copper/Mineral Options:
 - poolife® AlgaeBan II
 - poolife® Algaecide 90
 - POOL Breeze® Opticide®
 - Pool RX
 - Nature2 Express
- Polyquat Options:
 - poolife® Defend+®
 - GLB® Algimycin® 2000
 - POOL Breeze® Defender

- **How is the Clear Comfort system different from traditional water treatment systems?**

The Clear Comfort system using a patent Hydroxyl-Based Advanced Oxidation Process (AOP) to create hydroxyl radicals, the most powerful oxidative compounds available for recreational water treatment. Clear Comfort protects pool or spa water (biocide, scale control and corrosion control) without the harsh effects of salt chlorine, high cyanuric acid or high chlorine levels.

- **How does the Clear Comfort system work?**

Using a proprietary and patented technology, the Clear Comfort system creates a gas that, when added to water, forms hydroxyl radicals and safe amounts of hydrogen peroxide, which destroys aquatic microorganisms and controls organic material. The Clear Comfort system produces an excellent biocide, which kills bacteria, protozoa and viruses.

- **How long does installation take?**

Typically, installation should take a few hours. As soon as it is installed, it is ready to start treating the water immediately.

- **Where does the Clear Comfort system get installed?**

The Clear Comfort system needs to be within 10 feet of the pool or spa Manifold injection site. It can be installed either indoors (as long as there is access for the air handling) or outdoors. The system's Manifold is installed directly into the pool or spa plumbing.

- **Is the Clear Comfort system affected by temperature? Hot or cold?**

No, the Clear Comfort system is weatherproof for outdoor conditions.

- **How do I know the Clear Comfort system is working?**

When Clear Comfort system is ON and operating properly, both the Control Unit's green LED light and Cartridge Unit's blue LED light should be illuminated. See Figure 1 for proper LED function. If strange light pattern occurs, disconnect cable assembly and reconnect.

NOTE: This electrical connection must be made in accordance with the local electrical code.

Wiring to pump electrical circuit (preferred method)

The device must be properly connected to the correct power source (either 60Hz, 120V or 230V) using the supplied power cord in accordance with the local electrical code. The unit should be hardwired to the pump circuit and controlled by the pump circuit.

Wiring to a standalone electrical outlet (use when pump continuously operates)

If the unit is being wired to standalone AC power (i.e., not through the pump circuit on either 120V or 230V) it should be installed to operate only when the pump is operating with its own timer circuit and plugged in through a Ground Fault Circuit Interrupt (GFCI) and the timer should be set to reflect the pool pump hours of operation. The unit should not run when the pump is off. For questions regarding this operational mode please contact Clear Comfort at 303.872.4477.

230V power supply cord supplied and must be field wired in accordance to the NEC (ONLY FOR 230V).



For the latest version, please visit:
clearcomfort.com/ccw100-manual

For further assistance contact us:

303.872.4477
support@clearcomfort.com
clearcomfort.com