

PEGASUS PRODUCTS, INC.

Vinyl Liner Measuring Guide

TABLE OF CONTENTS

Introduction.....P.	1
Problems, things to watch for.....P.	1
Terminology and Definitions.....P.	2
Depths.....P.	3
Slopes.....P.	3
Length and Width.....P.	3
Rectangle.....P.	4
Oval.....P.	5
Grecian.....P.	6
Lazy Ell.....P.	7
Roman Ends	8
Straight Slope.....P.	9
Wedge.....P.	10
True Ell.....P.	11
Hexagon.....P.	12
Kidneys and Free Forms (A-B).....P.	13-14
Rectangle Step.....P.	15
Corner and Roman Step.....P.	16
Corners.....P.	17

The replacement liner installer and liner manufacturer share common goals in providing liners that conform to safety guidelines, that look good, and last a long time. Safety concerns are dealt with separately. In the following pages we will attempt to throw some light on how to measure for liners.

Accuracy is the key. Precise measurements are a must. Assumptions have no place in this endeavor. DO NOT attempt to make allowances for stretch or shrinkage no matter what the season. That is the manufacturers job.

PROBLEMS YOU MAY ENCOUNTER

1. If you have the manufacturers specifications, do not take these as necessarily being the correct dig dimensions for the pool. Often installers will change these dimensions before or during the dig.

2. A dished out or "bowl" shaped hopper. If there are no break lines, you should measure depths at grid points, wall height, and true lengths along the bottom of the pool for the length and width of the hopper. Also any other info you can supply is always helpful, i.e., cross sections, descriptions, photos, etc. *Ask for our concrete/bowl shaped measuring guide.

3. Finished wall height varies. If it does, by an inch or more, especially in the shallow end, make note of it if it cannot be leveled.

4. Be sure to check the shallow end depth at the end wall and at the transition break line. Often the shallow end will have a slight slope to it.

5. Check the slope of the sidewalls, especially on rectangles. Measure width and length of the pool at the top and bottom of the wall. If the difference at the top and bottom is more than 4 inches, let us know.

6. The shallow end may have a cove at the base of the wall. If so, indicate height of the cove and distance into the floor. Give the wall height to the top of the cove AND the shallow end depth to the floor.

7. If there is a safety ledge, you may give the slope measurements either to the edge of the ledge or all the way back to the wall. In either case, indicate which measurement you give and the size of the ledge. Again, do not assume, measure all ledges.

8. If diagonal cross dimensions are required, they are to be measured from a point where the straight walls meet when extended, NOT from the middle of a diagonal or radius.

TERMINOLOGY AND DEFINITIONS

A-Overall Width
B-Overall Length
C-Overall Depth
D-Shallow End Depth/Wall Ht.
E-Back Slope/End Slope
F-Pad Length/Hopper Bottom
G-Long Slope/Transition Slope
H-Shallow End/Wader
I-Side Slopes
J-Hopper Pad Width

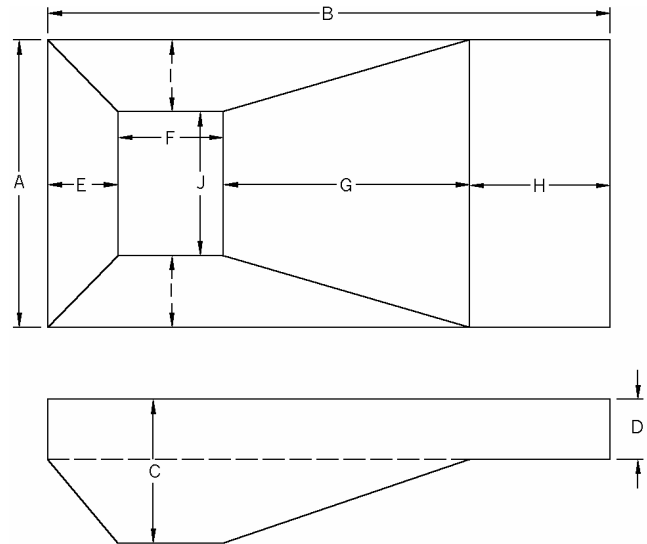

FINISHED DEPTH - The depth of the deep end and of the shallow end with a sand or vermiculite bottom, level and ready for a liner, or the depth to an existing liner from the bead or bead receiver to the pool floor.

BEAD - Thick, usually wedge shaped strip on the top of the wall to hold the liner in the receiver. Usually it is a good idea to send us a SAMPLE of the bead if it is rounded or hook shaped or if you are not sure if it is standard bead. There are many different types of bead.

BEAD RECEIVER - Small opening all around the pool beneath the coping into which the bead snaps. ALL DEPTH MEASUREMENTS ARE TAKEN FROM HERE.

TRUE LENGTH - This is NOT the length of the pool. This is the length of a slope or the bottom of a pool down one slope across the bottom and up the other slope. In other words, from the bottom of one wall to the bottom of the opposite wall keeping your tape measure on the ground. Do not give this measurement except with a bowl shaped hopper or if we request it.

BREAK LINE (BREAK POINT) - Any place on the floor of the pool where the angle changes.

COPING - The "cap" at the top of the wall at deck level, often extending past the plane of the wall and into the pool.

GENERAL DEPTH, SLOPE, LENGTH and WIDTH MEASUREMENTS

First we will cover the basics of measuring DEPTHS AND SLOPES. When measuring any slope, the measurement is of the horizontal distance of the slope, NOT the actual length of the slope on the pool floor. When measuring the side and back (end) slopes of any pool DO NOT ASSUME that any of the slopes are the same. Even if they look the same, measure them all. **Be sure to DOUBLE CHECK that your dimensions along the length of the pool add up to equal the total length of the pool and that your width dimensions equal the total width.

To measure the **SLOPES** of an **EMPTY** pool, simply hold a measuring stick or tape measure horizontally from the top of the slope, and drop a plumb bob from the ruler to where the slope meets the hopper pad and record this measurement.

To measure the **SLOPES** of a **FULL** pool, take a long pole and feel where the slope meets the hopper pad or where the long slope meets the shallow end. At that point, bring the pole to the coping at a 90 degree angle and make a chalk mark. This should be done for all break points first, both length and width, then measure the distance between the marks. For the first mark from the edge of the pool, measure from the inside of the wall, not from the coping.

To measure the **DEPTH** of an **EMPTY** pool, hold a measuring pole vertically from the **CORNER** of the hopper pad and run a string across the top of the pool. Record this height. NOW SUBTRACT the distance from the top of the coping to the bead receiver. Do not measure from the center of the pad as it may be deeper and consequently cause wrinkles.

To measure the **DEPTH** of a **FULL** pool, hold a measuring stick vertically at the corner of the hopper pad and note the depth of the water, then measure the distance from the water line to the bead receiver. Add these to get the finished depth.

When measuring the **LENGTH AND WIDTH** of a pool, measure **INSIDE** the pool from wall to wall **BELOW** the coping.

The following pages will discuss different measurements required for different types of pools.

NOTE: On symmetric pools (with no left or right bend) if you are requested to measure both walls, all four corners, measure diagonals, or several wall heights, PLEASE DO, although they need not be recorded unless there is a difference in any of them that might affect liner fit.

STANDARD RECTANGLES

- Measure overall length and width (A & B). Measure BOTH ends and BOTH sides. If walls are angled out, measure length and width at the top and bottom of the walls.
- Measure diagonals corner to corner AT THE BOTTOM of the wall. If they differ by more than 2 inches, indicate so.
- Measure wall height in the shallow end (D). Remember the possibility of coves and a sloping wader. (pg. 1)
- Measure the deep end depth (C). See page 3.
- Measure slopes and flat areas to all breaks for the length of the pool (E, F, G, and H). Be sure that they equal "B." pg. 3
- Measure side slopes and pad width (I, J, I). Measure BOTH side slopes. Your total should equal "A".

NOTE: If the pool is a tri-level, all steps are the same. There will be 2 more measurements for the length of the pool, 2 extra side slopes, and an extra depth measurement.

See page 1 for safety ledge, pages 15-17 for steps and corners.

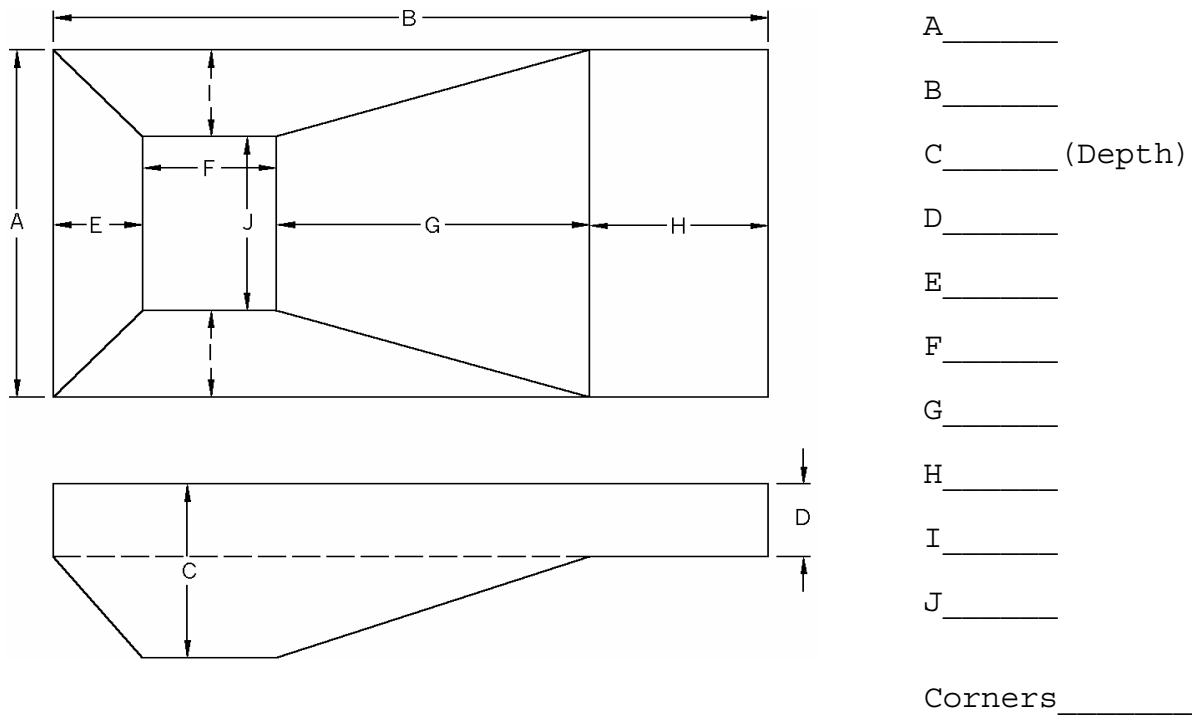

OVAL

- Measure the overall length and width (A & B). Measure the width at the ends of the straight walls.
- Measure the diagonals shown in dotted lines below (RU & TS). These are from the ends of the straight walls.
- Measure both of the straight walls (RS & TU).
- ** IF there are no straight walls (true oval) or if the diagonals differ by more than a few inches then the pool must be measured like a freeform (see section on Kidneys & Freeforms).
- Measure the slopes and flat areas for the length of the pool (E, F, G, & H). These should add up to the overall length (B). (pg. 3)
- Do the same for the side slopes and pad width (I, J, I). These should add to the total width (A). Again do not assume that ANY of the slopes are the same.
- Measure the hopper depth (C) and shallow end depth (D).
- Note any IRREGULARITIES such as a straight panel at either end or a square hopper pad. Otherwise, we must assume the standard oval layout.
- Measure the straight portion of the pad length (K)

* IF the oval has a vinyl covered STEP:

1. See the measuring instructions on page 15.
2. If the step is located anywhere other than in the exact center of the pool, take measurements from the ends of the straight walls to the corners of the step.

If there is a STRAIGHT step that does NOT need to be covered, but needs a straight cut, indicate its location in the same manner and we will incorporate that in the liner.

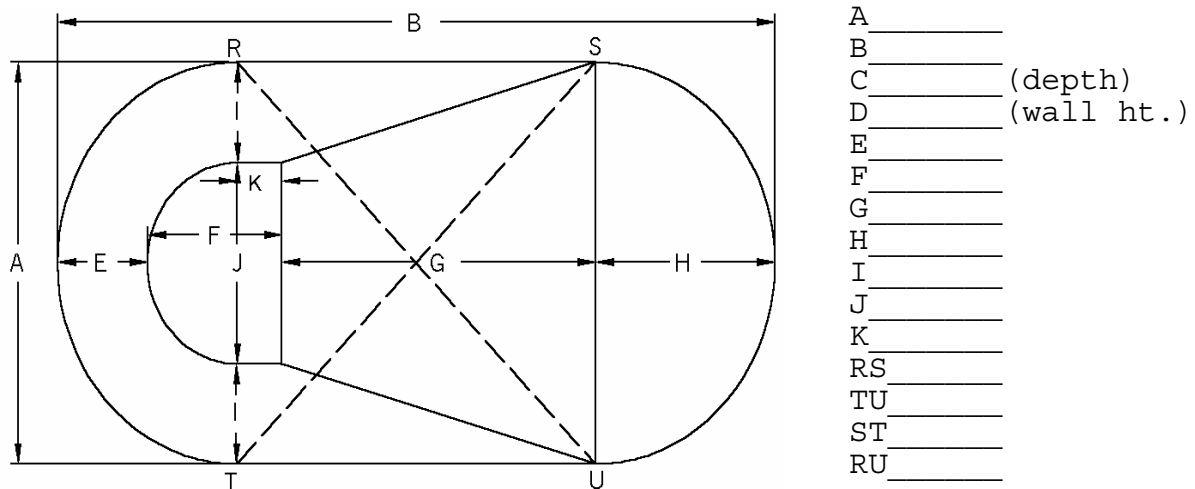

GRECIAN

- Measure both long walls (M), both end walls (L), and all 4 corner panels (K).
- Measure the overall length and width (B & A).
- Measure the two diagonals from the end of one long wall to the opposite end of the other (SO & TP). If these are significantly different, then take 4 more diagonals from long wall to end wall (RO, QT, SN, PU).
- Measure the four components of length (E,F,G,H pg.3). Be sure that they equal the length (B).
- Do the same for the side slopes and the pad width. Measure both slopes and be sure that they (I,J,I) add up to equal the total width (B).
- Measure the wall height (D) and hopper depth (C). (pg. 1 & 3)
- Indicate whether the PAD is GRECIAN shaped (chamfered) OR SQUARE.
- If the BACK SLOPE DIFFERS FROM THE SIDE SLOPES by more than 6 inches, and the pad is grecian shape, you will have to measure all the straight edges of the pad. Include sketch.

See page 1 for safety ledge, page 15 for step measuring

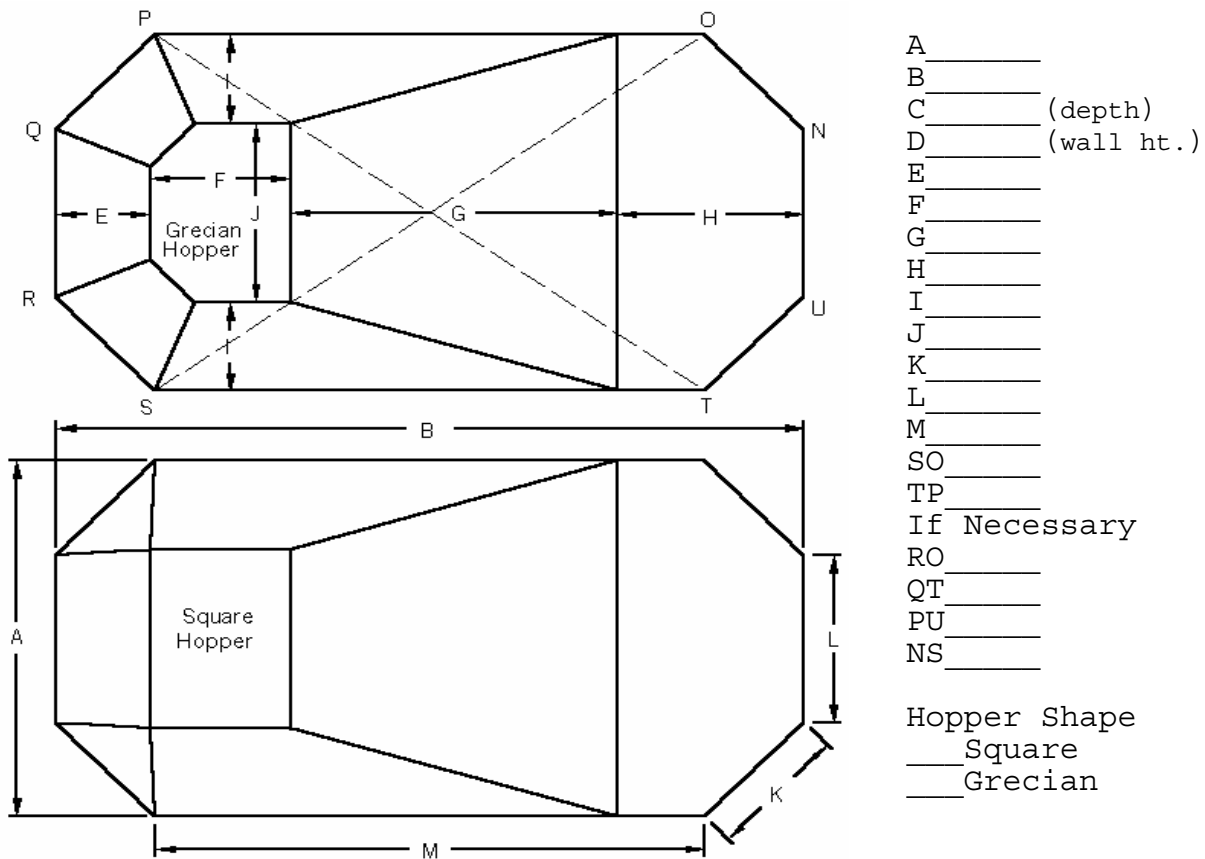

LAZY ELL

- Measure the four side walls (2,3,5,6) and two ends (1,4).
- Add the length of the long side of the hopper end to the short side of the shallow end (2+5). Also add the short side of the hopper end to the long side of the shallow end (6+3). If these are different, if the 2 end walls are different, OR if you suspect that the pool may be out of square, then measure the diagonals shown on the drawing (KO,PL,LN,MO).
- Measure the back slope, pad length, and long slope (E,F,G).
- Measure both side slopes and the pad width (I,J,I). These should equal the overall width (A).
- If the shallow end break line follows the bend in the pool (O-L) then indicate this and do not give the transition slope dimension.
- Do not give a shallow end dimension (H) if the break line is not straight across the pool. If supplying a shallow end measurement, be sure it is accurate, from 90° corner to perpendicular to the break line.
- Measure the shallow end depth (D) at the back wall and at the break line and measure the hopper depth (C) at the corners of the pad.
- Indicate the direction of the bend of the pool standing at the deep end.

See page 1 for safety ledge. pages 15-17 for corners and steps.

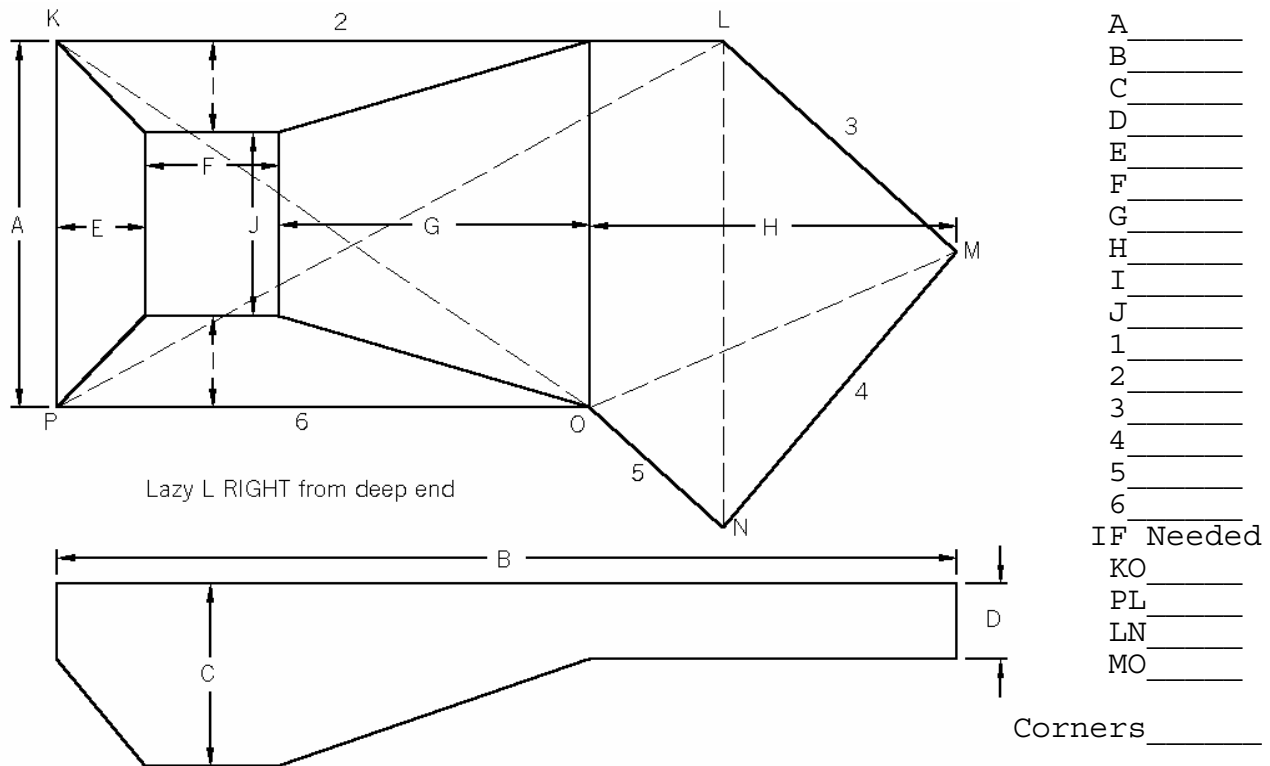

ROMAN END

- Measure overall length and width (A & B1). Measure BOTH straight sides (B2) and the width at both ends.
- Take diagonals, corner to corner, AT THE BOTTOM of the wall. If they differ by more than 2 inches, indicate so.
- Measure the wall height in the shallow end (D). Remember the possibility of coves and a sloping wader. (pg. 1)
- Measure the deep end depth (C). See page 3.
- Measure slopes and flat areas to all breaks for the length of the pool (E,F,G,and H). Be sure that they equal "B1."
- Measure side slopes and pad width (I,J,I). Check both side slopes. The total should equal the width (A).
- Measure the straight panels on each side of the bows, including the corner, at BOTH ends of the pool (L & M).
- Measure the distance straight back from the short panel to the end of the bow for both ends. (N & P).
- Some roman ends have square hoppers. If so, note it. If not, measure the straight side of the hopper (K).

NOTE: If there is a straight step on a double roman end, all measurements will be the same, but indicate that there is a straight step, and that measurements are taken to the front of the step. For SINGLE roman ends, all measurements are the same, except "M" and "P" are ignored.

See pages 15-17 for steps and corners.

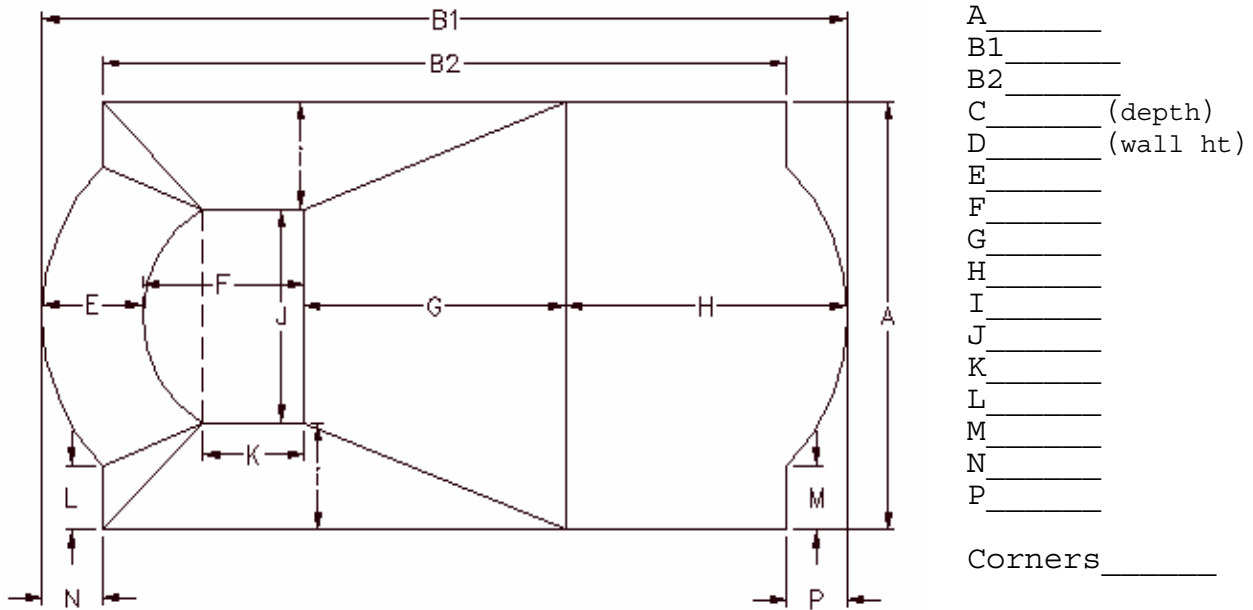

STRAIGHT SLOPE

- Measure overall length and width (B & A).
- Measure BOTH ends and BOTH sides. If walls are angled out, measure length and width at the top AND bottom of the walls.
- Measure diagonals corner to corner. If they differ by more than 2 inches, indicate so.
- Measure wall height in the shallow end (D).
- Measure the deep end depth (C). See page 3.
- There may or may not be a flat area in the deep end or in the shallow. If either exists, provide dimensions (F,G,H) as needed. Be sure that they equal "B".
- If there is a flat deep or shallow area, BE SURE to get depths at the front and back (corners and break lines). They are often not actually flat on straight slopes.
- If the long slope does not appear to be a straight line, or if you are not sure if it is, give depths along both long walls every 3 feet or so for the entire length of the pool. Indicate the interval used. If this is done, include a sketch.

NOTE: A straight slope has no side or back slopes, but be sure to check carefully for sloping walls. Even a slight slope to the walls can make a big difference in the fit of the liner.

See pages 15-17 for steps and corners.

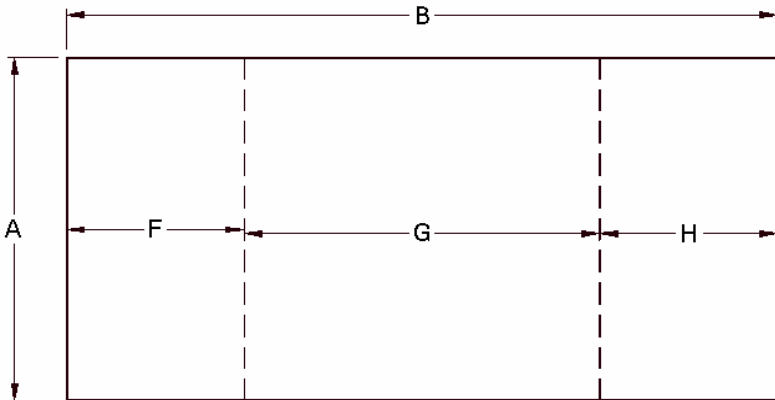

A= _____

B= _____

C= _____

D= _____

F= _____

G= _____

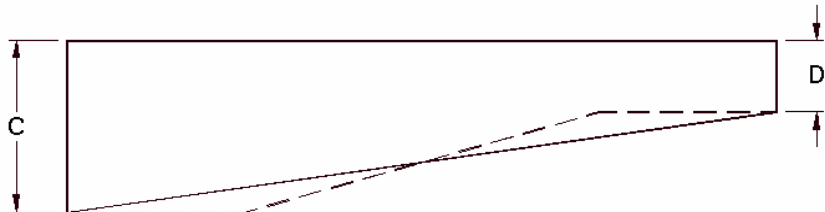

H= _____

Corners _____

WEDGE RECTANGLE

- Measure overall length and width (B & A). Measure BOTH ends and BOTH sides. If walls are angled out, measure length and width at the top and bottom of the walls.
- Measure diagonals, corner to corner, AT THE BOTTOM of the wall. If they differ by more than 2 inches, indicate so.
- Measure wall height in the shallow end (D).
- Measure the deep end depth (C). See page 3.
- Wedges may or may not have a flat shallow end area. Measure slopes and flat areas to all breaks for the length of the pool (E,G, and H if required). Be sure that they equal the length (B). (pg. 3)
- Measure side slopes and pad width (I,J,I). Measure both side slopes. Your total should equal the length (A).

See page 1 for safety ledge, pages 15-17 for steps and corners.

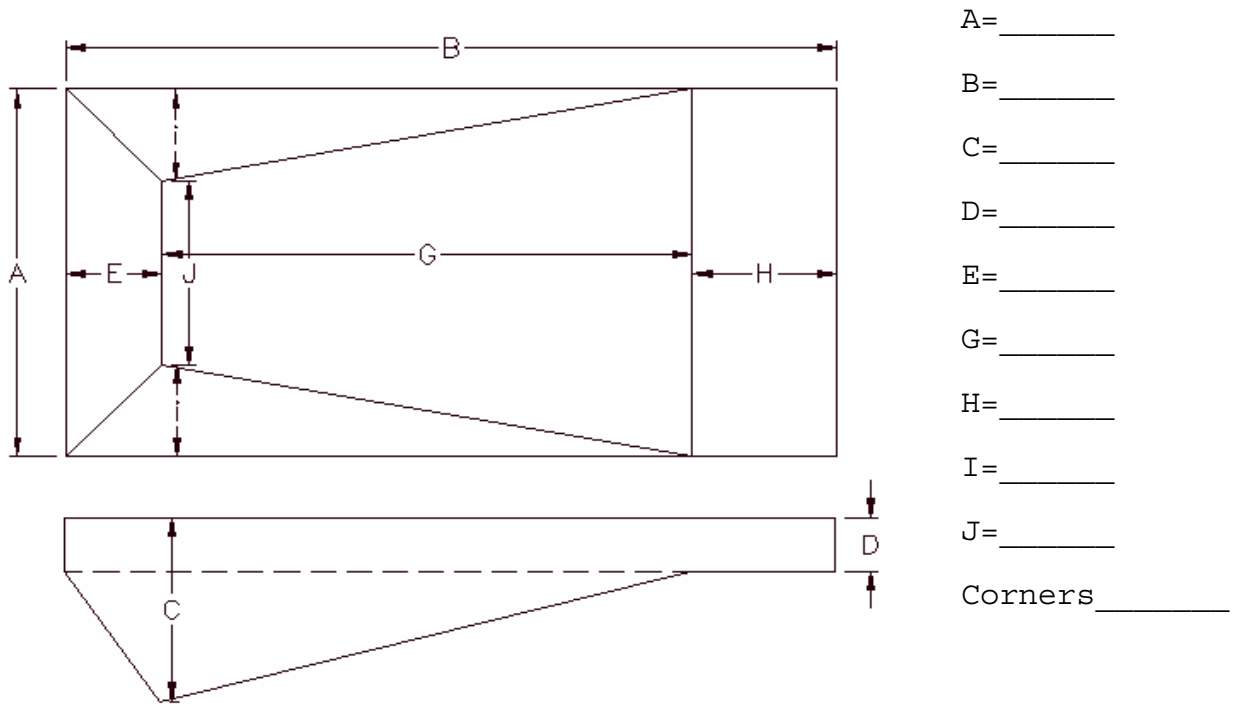

TRUE ELL

- Measure overall length and deep end width (B & A). Also shallow end length and width (W & L).
- Measure the deep end width and shallow length (A2 & W2) at or just before the bend.
- If 'A2' and 'W2' differ from 'A' and 'W' by more than an inch or so, or if you suspect that the pool may be out of square, take diagonals 1-5, 2-6, 3-5, 2-4.
- Measure wall height in the shallow end (D).
- Measure the deep end depth (C). See page 3.
- Measure slopes and flat areas to all breaks for the length of the pool (E,F,G, and H). Be sure that they equal 'A'. 'H' may not equal 'W'. Don't assume.
- Measure side slopes and pad width (I,J,I). Measure both side slopes. Your total should equal the width (B).
- Note the type and size of the INSIDE corner.
- Indicate the direction of the bend of the pool standing at the deep end, and include a sketch!

NOTE: If the pool is a tri-level, all steps are the same. There will be 2 more measurements for the length of the pool, 2 extra side slopes, and an extra depth measurement.

See page 1 for safety ledge, pages 15-17 for steps and corners.

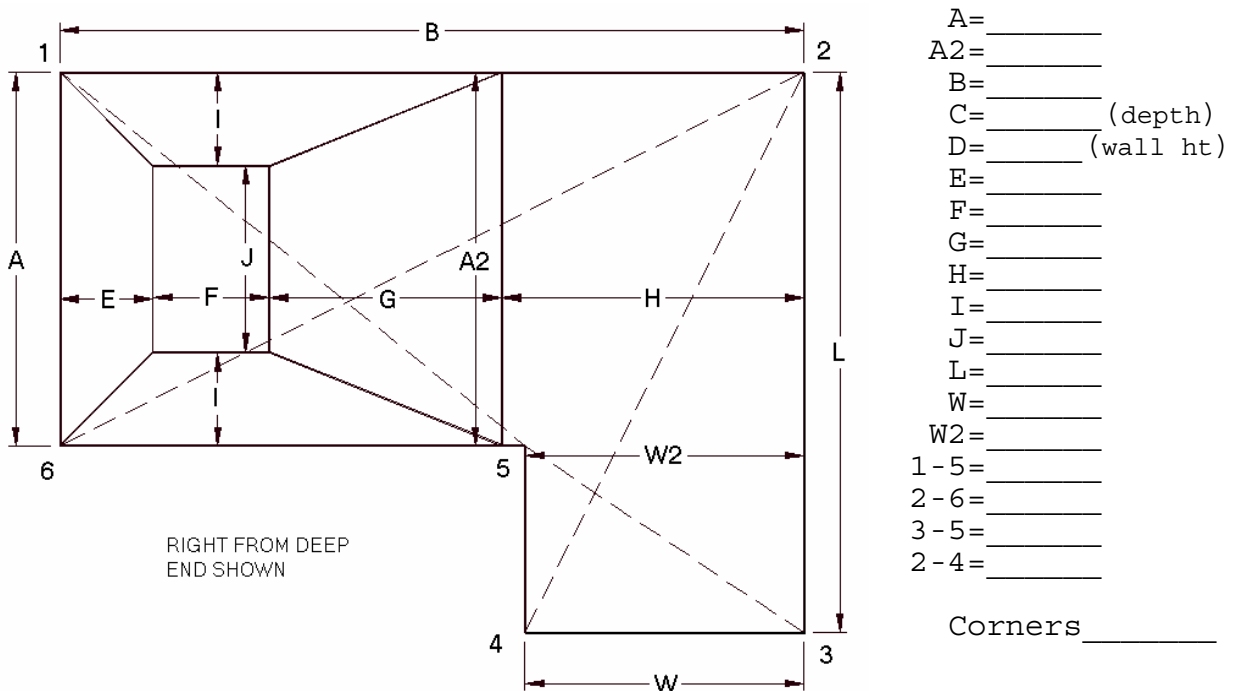

HEXAGON

- Measure overall length, end width, and middle width (B,A1 & A2). Measure BOTH ends to be sure they are equal.
- Measure the straight walls in the deep end AND the shallow (L1 & L2).
- Measure wall height in the shallow end (D). Remember the possibility of coves and a sloping wader. (pg. 1)
- Measure the deep end depth (C). See page 3.
- Measure slopes and flat areas to all breaks for the length of the pool (E,F,G, and H). Be sure that they equal 'A'. (pg. 3)
- Measure both side slopes (I). Also, pad width at the front and back (J1 & J2). Unlike other pools, there is no double-check for the width.

NOTE: It is a good idea to measure the straight walls on both sides of the pool, as well as the length on both sides. Also, as with any pool, it is a good idea to measure some diagonals to check symmetry. If anything seems out of square, note the diagonals that are off.

See page 1 for safety ledge, pages 15-17 for steps and corners.

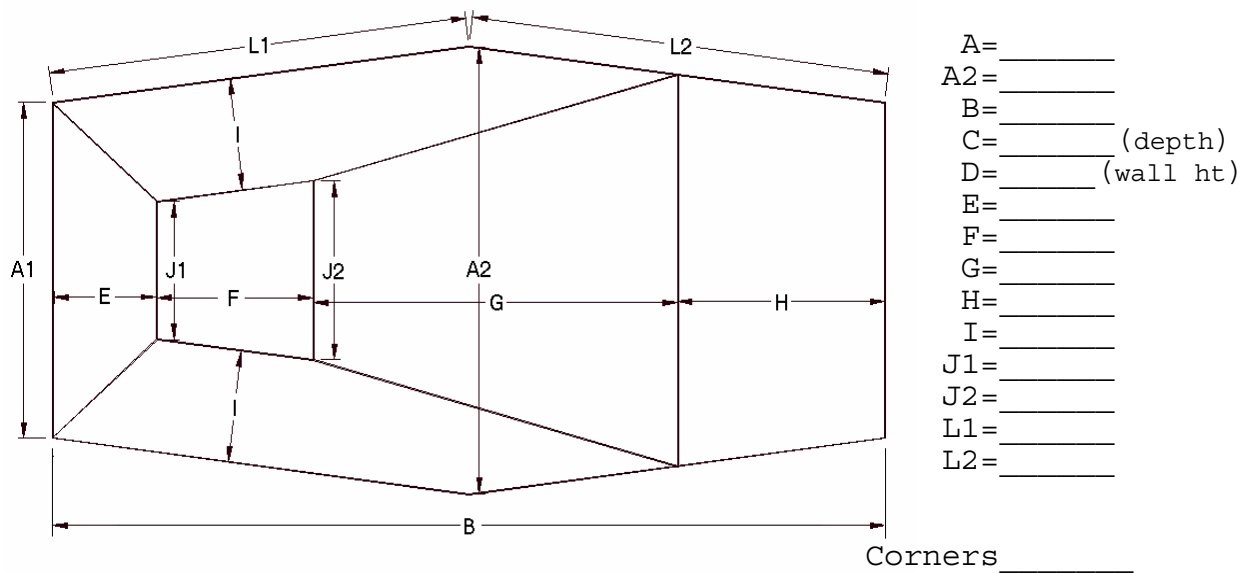

KIDNEYS AND FREE FORMS (A-B Method)

- Select and mark 2 points outside the pool on a long side, at least 3 feet from the pool, and approximately $\frac{2}{3}$ the length of the pool apart, and RECORD THAT DISTANCE. These are your A & B points. **NOTE:** An imaginary line extended between these points and beyond both ends should not come within 3 feet of any part of the pool. "A" should always be on the left if the line is between you and the pool. See following page.
- Mark points around the edge of the pool at the BEAD RECEIVER, NOT the edge of the coping, approximately 2-3 feet apart (1 foot or so on a tight radius). Put marks at the shallow end break line on both sides. Also at the deep end break. This line does not extend to the wall, so you will have to sight this line yourself. (see pg.14) Also mark any corners, ends of steps, etc. NUMBER ALL of these marks.
- Measure from point A to point 1 and from B to 1. Record the measurements on a chart like the one shown. Repeat for all points and INDICATE WHICH NUMBERS ARE AT THE BREAK LINES. For example, if points X1,X2,X3,X4 correspond to points 18,29,41,5 (pg.14) they are marked on the chart as shown.
- Indicate whether the transition slope lines are straight or curved (see drawing).
- Measure the back and side slopes, and the hopper pad length and width (pg. 3).
- Measure the shallow end from the center of the break line to the center of the shallow end wall.
- Measure horizontally from the left corner of the shallow end to the left corner of the hopper pad, and the same for the right side (V to X2 & T to X4).
- Measure the shallow end depth and the hopper depth at the corners of the pad (pg. 3).
- Measure the perimeter of the entire pool at the bead.
- If there is a step, indicate its location by marking points at each corner of the step and assigning numbers to them. On the form, indicate which points correspond to the step corners. For added accuracy you can measure from one or both of the shallow end "corners" to both step corners (X2 to S & X2 to R).
- Indicate the direction of the pool and the end you are standing at to determine this (ie. left from deep end). Also include a rough sketch showing the direction, location of the A & B points, and bottom configuration.
- Measure longest, widest and a few cross dimensions, indicating which points are the end points for the measurements.

See page 15 for step measuring.

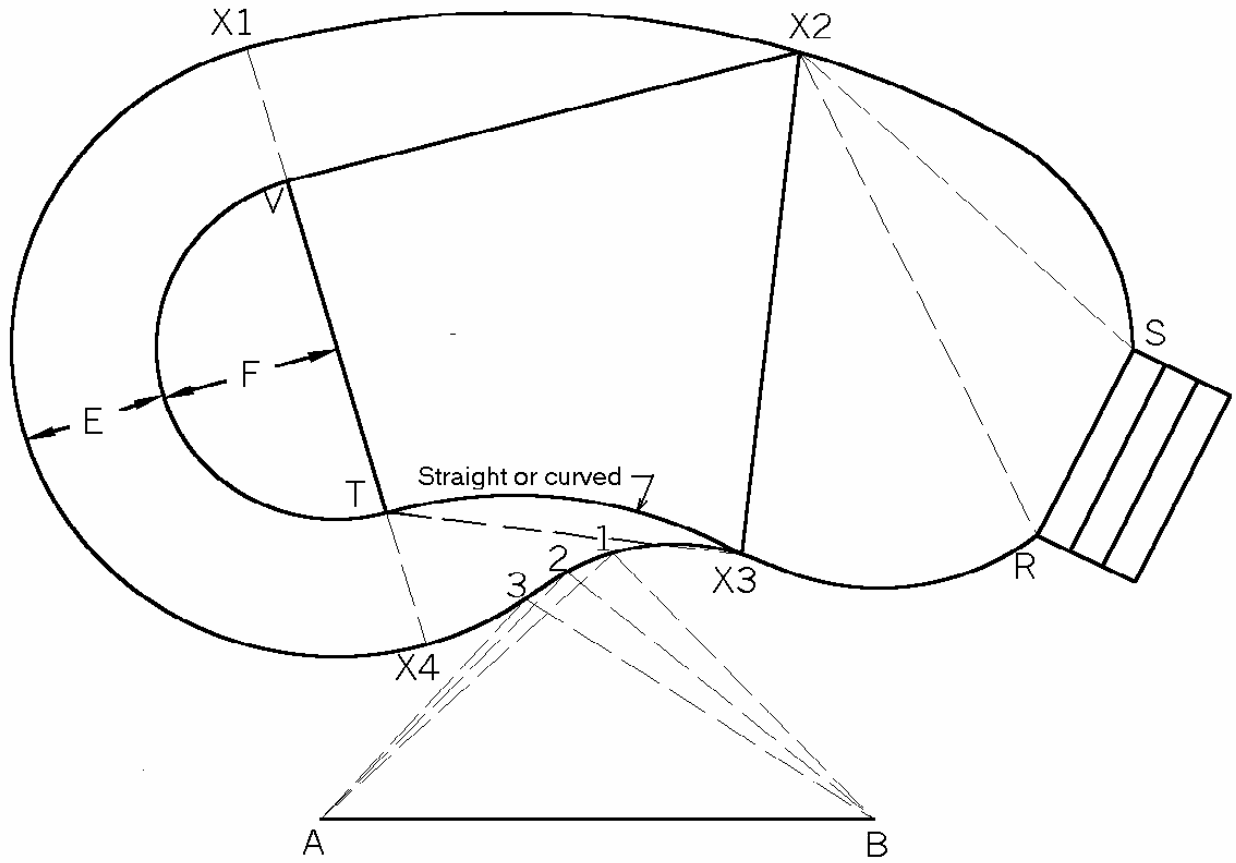

X1, X2, X3, and X4 are break line location points which must be marked and given numbers.

	A	B		A	B		A	B		A	B
1			17			33			49		
2			18			34			50		
3			19			35			51		
4			20			36			52		
5			21			37			53		
6			22			38			54		
7			23			39			55		
8			24			40			56		
9			25			41			57		
10			26			42			58		
11			27			43			59		
12			28			44			60		
13			29			45			61		
14			30			46			62		
15			31			47			63		
16			32			48			64		

VINYL COVERED STEPS

NOTE: Steps should be measured without a liner in place, if you MUST measure a step with a liner in place, be sure to measure to flat surfaces on the step, not seams in the liner.

Rectangular

- Measure all risers; R1,R2,R3,R4 (R5 if it is a 4-tread step). The risers should equal the shallow end depth.
- Measure all treads; T1,T2,T3 (T4 if a 4 tread step)
- Measure the total length of the step across the inside along any tread.
- Measure the total width of all of the treads from the back wall of the step to the pool wall.
- Indicate if the bottom step is set back from the pool wall. If so, measure the distance. Also indicate if the set back is straight or on a diagonal. Sketch it if necessary.
- Give the type of corner at the back AND front of the step.
- Give/sketch the location of the step. If it is not at the center of the shallow end or flush against a corner, then give the distance from the closest corner.
- Indicate if the step needs pockets for rods or tabs for nailing.

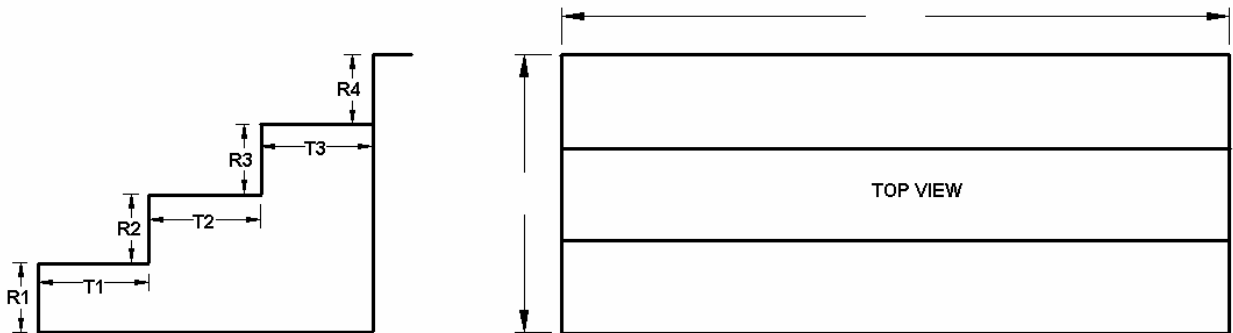

R1=_____ R5=_____ (If 4 tread step)
 R2=_____ T4=_____ (If 4 tread step)
 R3=_____ Length_____
 R4=_____ Width_____
 T1=_____ Top Corner: ____SQ. ____RAD. ____DIAG.
 T2=_____ Top Corner Size: _____inches
 T3=_____ Recess: Y N _____inches
 Straight diagonal

Corner Step

- Measure all treads and risers the same as for a rectangular step.
- Measure the length of the front of EACH tread.
- Indicate the top tread corner type and size.
- Take a measurement from the corner to the end of the bottom tread as shown.
- Indicate if the back of the step needs rod pockets or flaps.

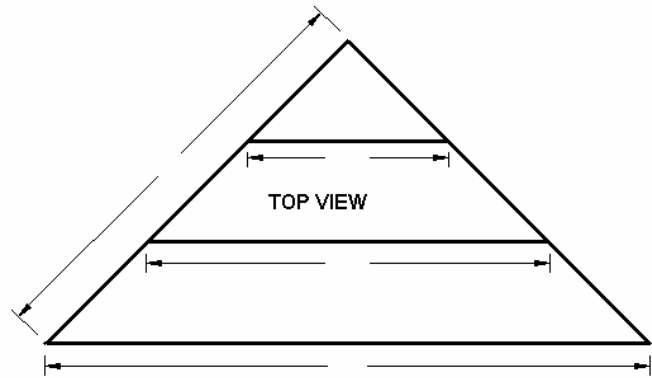
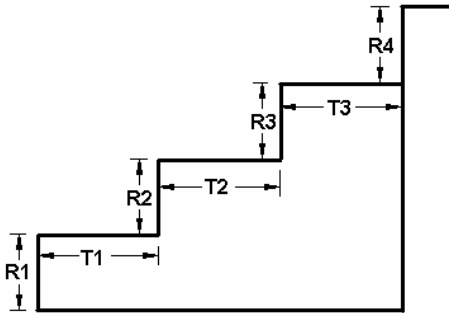

Radius (Roman) Step

- Measure all treads and risers, the same as for a rectangular or corner step.
- Measure the length of the front of EACH tread.
- Indicate if the back of the step needs rod pockets or flaps.
- Indicate if there is a set back, and its size.

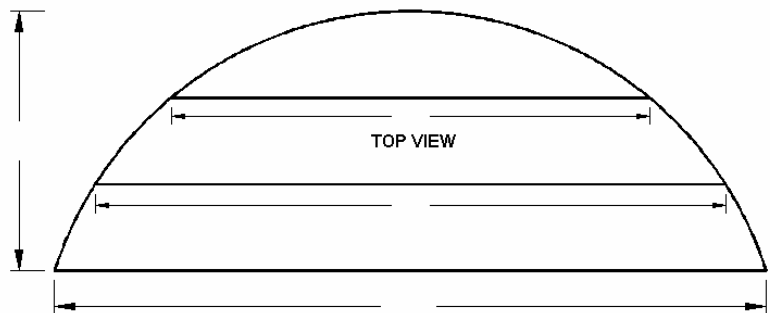
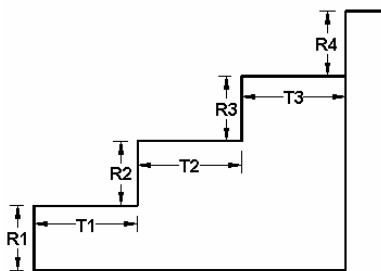

CORNERS

SQUARE CORNERS: Simply indicate square (or 90 degree)

DIAGONAL CORNERS: Indicate diagonal corners and measure across the face of the corner to get the diagonal size.

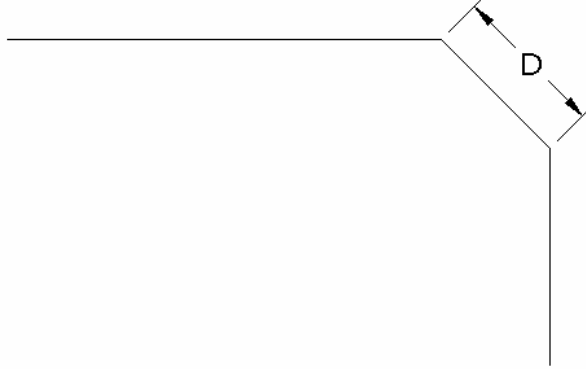

RADIUS CORNER: Indicate radius. Extend a line straight out from the two walls at the corner. Measure from where these two lines meet back to the beginning of the corner. See drawing below.

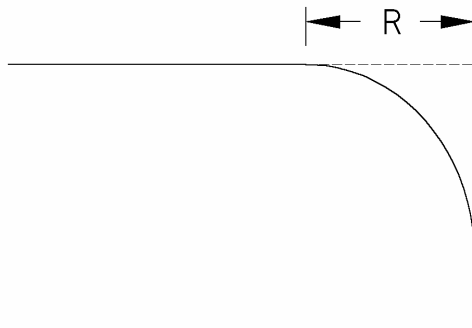

FEEL FREE TO CALL US IF YOU HAVE ANY QUESTIONS